

Stability Chamber(GS series:150L-500L)

Labonce-GS Medicine Stability Testing Chamber, Adopt imported with frequency conversion technology design, Choose the original imported high quality parts, Stable and reliable performance, Suitable for GMP and CGMP certified users.

- ◆ Reference Standard: ICHQ1(A)、 Chinese Pharmacopoeia 2020 edition;
- ◆ Insulation material: Overall high-density polyurethane foam technology, with good insulation and moisture retention performance;
- ◆ Chamber Materials: The exterior is coated with high quality steel plate, The liner is made of mirror stainless steel 304, no pollution source, easy to clean;
- ◆ Control system: Programmable color touch screen controller;
- ◆ Three Level Authority: Adopt the user name and password to log in. Different user names have different permissions at least three levels or above;
- ◆ Audit tracking: The control system has historical alarm recording and operation recording functions, and supports exporting in an unchangeable file format using a USB flash drive;
- ◆ Refrigeration system: Imported fully enclosed compressor;
- ◆ Humidity control: Original imported capacitive humidity sensor, high precision, low drift, long service life, maintenance free;
- ◆ Data management: configuring needle micro printers and electronic data storage functions;
- ◆ Safety device: Compressor overheat and overpressure overload protection, water shortage protection, Anti dry burning protection system, independent overtemperature protection alarm system;
- ◆ Alarm system: On-site beeping alarm;
- ◆ Double Door structure: Interior door tempered glass door, Open the outer door to observe the sample, The temperature and humidity inside the container will not change in a short time, The outer door is solid can keep temperature and humidity, It can also prevent the influence of external light;
- ◆ Controlling Temperature Precision: Temperature Fluctuation < $\pm 0.5^{\circ}\text{C}$; Temperature Deviation < $\pm 1.0^{\circ}\text{C}$;
- ◆ Controlling Humidity Precision: Humidity Fluctuation < $\pm 2\%\text{RH}$; Humidity Deviation < $\pm 3\%\text{RH}$;
- ◆ Power: AC220V $\pm 10\%$ 50HZ;
- ◆ Environment Temperature: +5 ~ 35 $^{\circ}\text{C}$;
- ◆ **Optional:** Temperature-humidity deviation, sudden power failure, Remote SMS alarm.

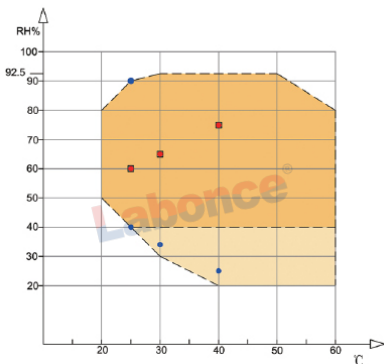

◆ Temperature and humidity control range diagram



◆ Mirror stainless steel 304



◆ 150GS~500GS

Model	Temperature Range (°C)	Humidity Range (RH)	Capacity (L)	Interior Dimensions(mm) W×D×H	External Dimensions(mm) W×D×H	Power (kW)	Shelf (Standard)
Labonce-150GS	10 ~ 65	20 ~ 95%	150	600×405×620	780×830×1480	1.2	3
Labonce-250GS	10 ~ 65	20 ~ 95%	250	600×500×830	780×880×1650	1.5	3
Labonce-400GS	10 ~ 65	20 ~ 95%	400	600×700×950	780×1060×1750	2.0	3
Labonce-500GS	10 ~ 65	20 ~ 95%	500	680×680×1080	860×1050×1850	2.2	4

All indicators on this color page were measured at an ambient temperature of 20~25 $^{\circ}\text{C}$.

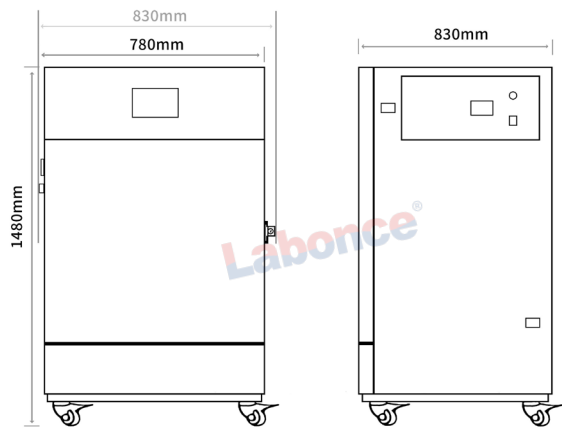

◆ 150GS

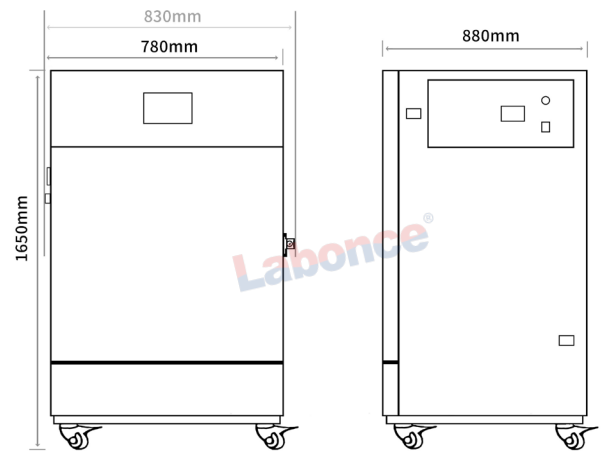

◆ 250GS

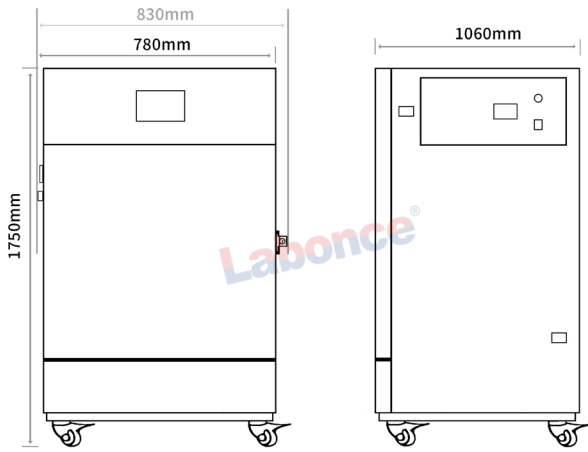

◆ 400GS

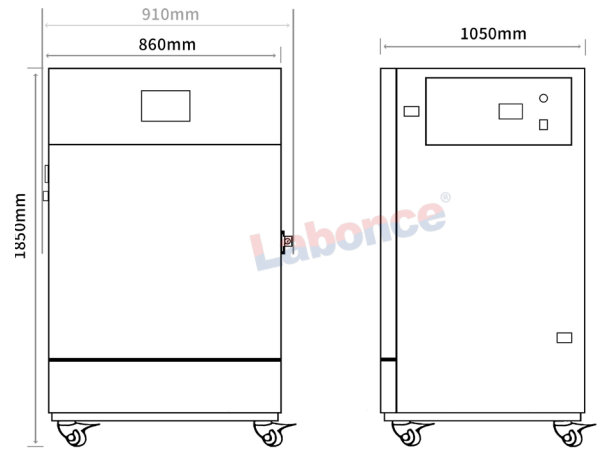

◆ 500GS

